

## MPCS-5

The **MPCS-5** is a microplate processing conveyor system designed to integrate up to five processing functions on a single conveyor. The MPCS-5 is offered in “Day 1” or “Day 2” configuration (functions that can be installed on each are listed below). Each conveyor has five available positions, but some Day 1 functions require more than one position. Day 2 functions can be arranged in any sequence on a Day 2 conveyor. All are available for 96 or 384 well plates.

### Day 1 MPCS-5

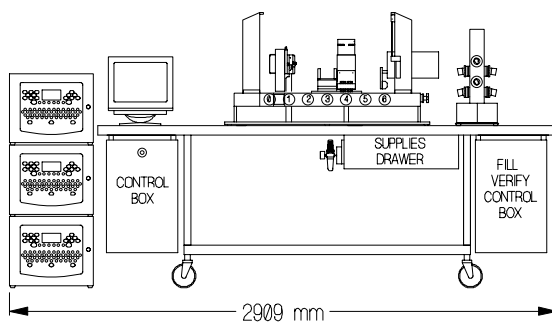

### Day 1 Functions

- Ink jet printing on trays
- Ink jet printing on tabs
- Air purge (of wells)
- Precision dispensing (and bubble detection)
- Fill verification
- Bar code reading

### Day 2 MPCS-5

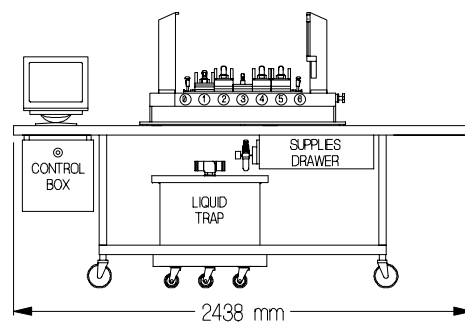

### Day 2 Functions

- Combined wash and aspirate
- Washing
- Aspiration
- Blocking
- Drying
- Bar code reading